



MACHAKOS UNIVERSITY

University Examinations 2016/2017

SCHOOL OF ENGINEERING AND TECHNOLOGY

DEPARTMENT OF ELECTRICAL AND ELECTRONICS ENGINEERING

THIRD YEAR FIRST SEMESTER DIPLOMA IN MECHANICAL ENGINEERING

MED/PR 303: CONTROL SYSTEMS

DATE: 28/7/2017

TIME: 2:00 – 4:00 PM

INSTRUCTIONS:

Attempt Question One and Any Other Two Questions

QUESTION ONE (COMPULSORY) (30 MARKS)

- (a) List any two advantages of open loop over closed loop control systems (2 marks)
- (b) State with reasons whether the control system used in each of the following systems is closed loop or open loop
- (i) furnace temperature controller
- (ii) washing machine (8 marks)
- (c) Determine the transfer function of the network shown below

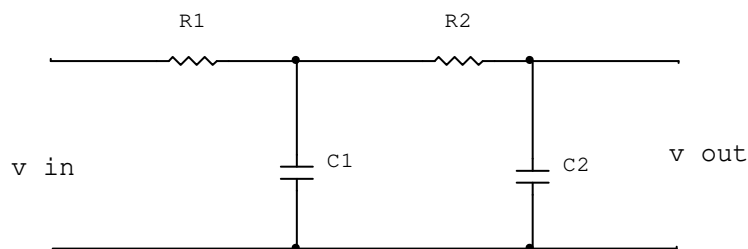

(10 marks)

- (c) With an aid of a canonical block diagram of a closed loop system derive

- (i) closed loop transfer function
- (ii) error ratio
- (iii) primary feed back ratio. (9 marks)
- (d) State one advantage of feedback in a control system (1 mark)

QUESTION TWO (20 MARKS)

For the system shown below, determine

- i) open loop transfer function
- ii) closed loop transfer function
- iii) error ratio
- iv) feed back transfer function.

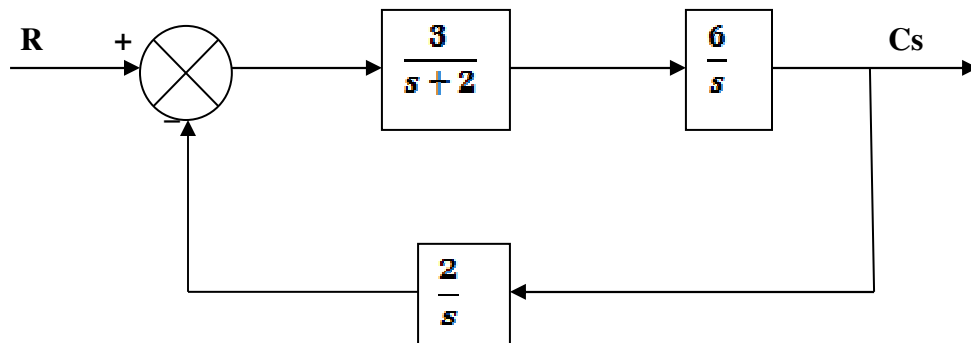

(20 marks)

QUESTION THREE (20 MARKS)

Using the block diagram algebra, reduce the block diagram of figure below to its canonical form and hence determine

- i) forward transfer function
- ii) feed back transfer function
- iii) error ratio
- iv) primary feedback ratio
- v) open loop transfer function

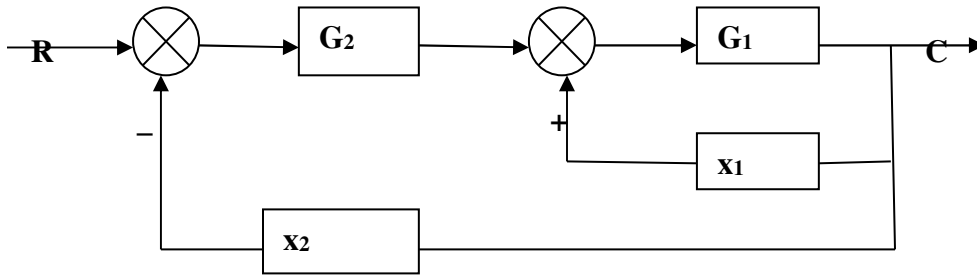

(20 marks)

QUESTION FOUR (20 MARKS)

(a) For the multi input system below, obtain the transfer function

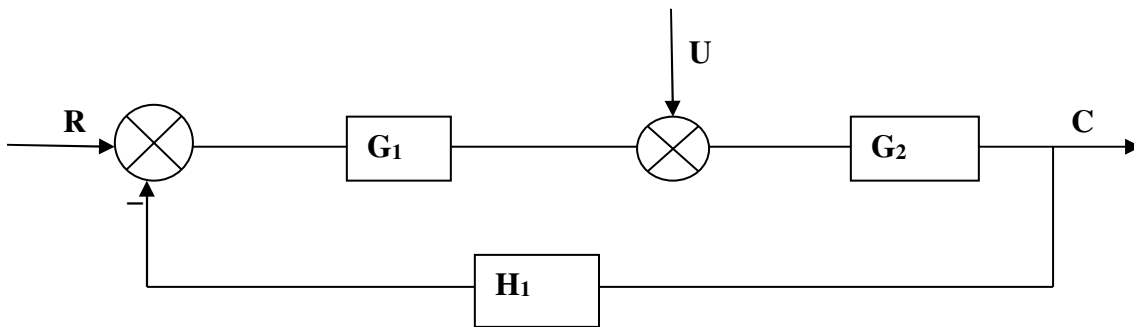

(10 marks)

(b) Differentiate between the following (i) manipulated variable

(ii) feedback element and feedback path 10 marks)

QUESTION FIVE (20 MARKS)

A mechanical system consisting of of a mass M attached to a spring (of stiffness K) and a dash pot (viscous friction coefficient f) on which a force F operates as shown below.

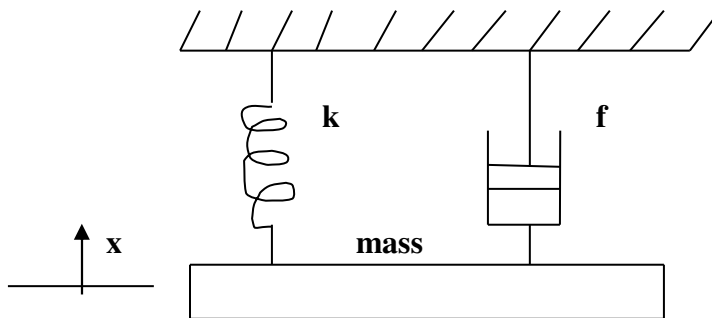

derive the transfer function.

(20 marks)